

DF-CPD PILOT TO CLOSE CHECK VALVE, GUIDED BALL

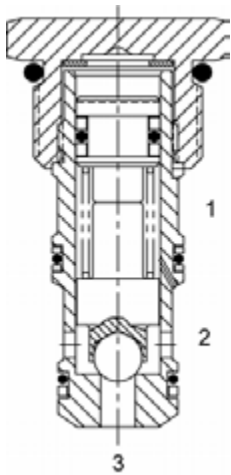

DESCRIPTION

10 size, 7/8-14 thread, "Delta" series, pilot to close, ball check valve.

OPERATION

The DF-CPD allows free flow from (3) to (2), and blocks flow from (2) to (3). Flow will be blocked from (3) to (2) when sufficient pressure is applied at (1). The cartridge has various "pilot ratios" (see options).

Example: 1/4 for 4:1 of the load pressure held at (3) is required at (1) to close the valve. The check is spring biased to assure holding in static or no-load conditions.

FEATURES

- Hardened parts for long life.
- Industry common cavity.

HYDRAULIC SYMBOL

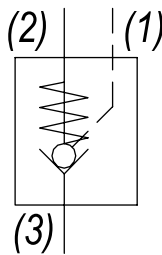

Consult chart for flow operation of each model. Special higher bias spring values available. Consult factory.

PERFORMANCE

Actual Test Data (Cartridge Only)

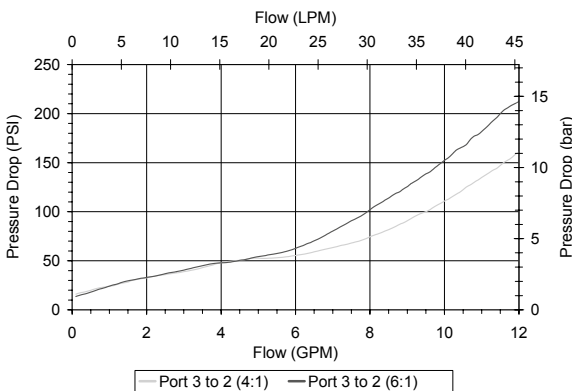

VALVE SPECIFICATIONS

Maximum Flow	10 GPM (38 LPM)
Rated Operating Pressure	3500 PSI (241 bar)
Typical Internal Leakage (150 SSU)	50 drops/min from (2) to (3) 5 drops/min from (3) to (2) when port (1) is piloted
Pilot Ratio	(see options)
Viscosity Range	36 to 3000 SSU (3 to 647 cSt)
Filtration	ISO 18/16/13
Media Operating Temp. Range	-40° to 250°F (-40° to 120°C)
Weight	.20 lbs (.09 kg)
Operating Fluid Media	General Purpose Hydraulic Fluid
Cartridge Torque Requirements	30 ft-lbs (40.6 Nm)
Cavity	DELTA 3W
Cavity Form Tool (Finishing)	40500001
Seal Kit	21191202

WARNING: the specifications/application data shown in our catalogs and data sheets are intended only as a general guide for the product described (herein). Any specific application should not be undertaken without independent study, evaluation, and testing for suitability.



4484 Boeing Drive Rockford, IL 61109 • USA • Phone +1 (815) 397-6628 • Fax +1 (815) 397-2526
mail: delta@delta-power.com • www.delta-power.com



Via Malavolti, 36 • 41122 Modena • ITALY • Phone +39 (059) 254895 • Fax +39 (059) 253512
mail: tecnord@tecnord.com • www.tecnord.com

DIMENSIONS

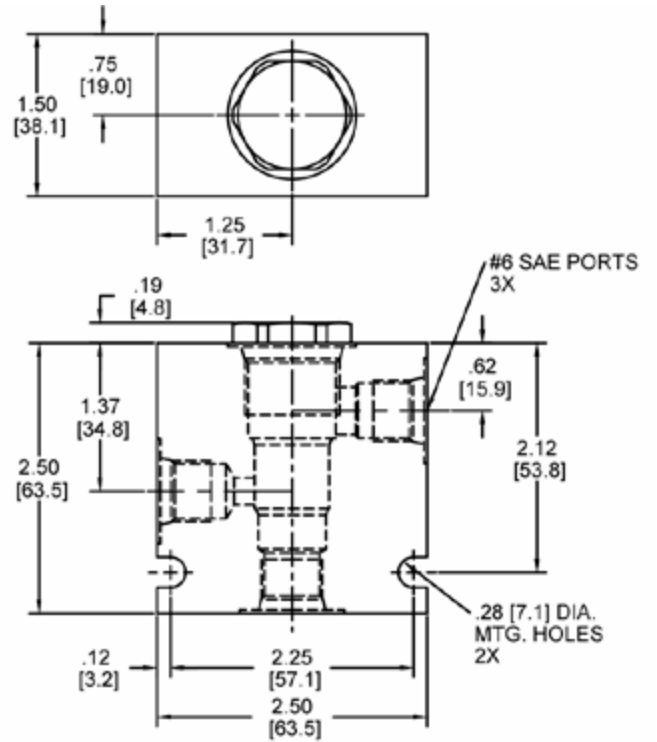
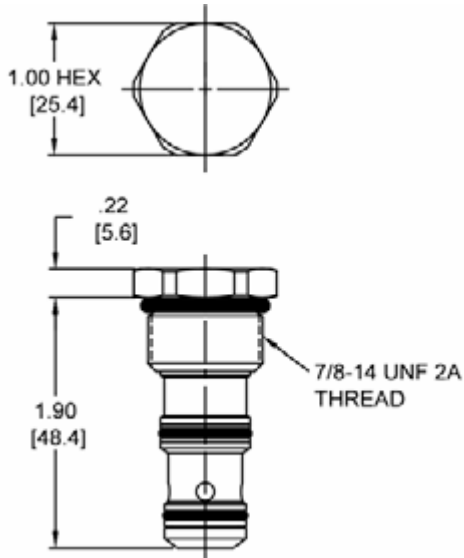

Body Weight: .76 lbs (.35 kg)

ORDERING INFORMATION

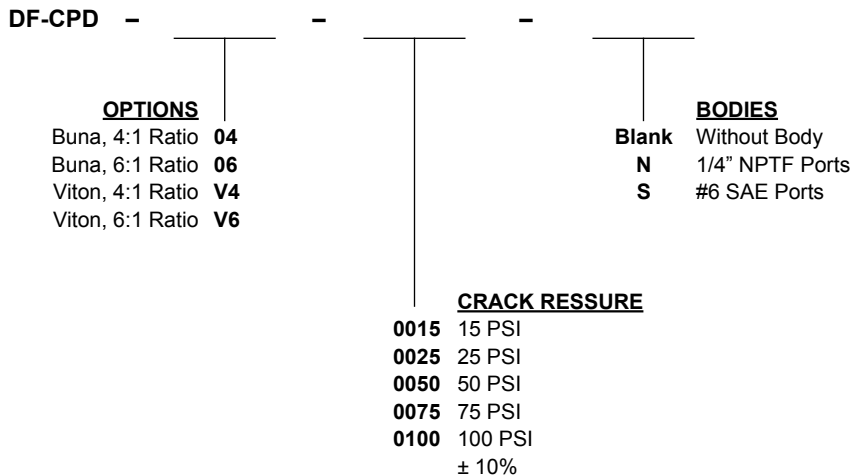

W 40 / 2017

WARNING: the specifications/application data shown in our catalogs and data sheets are intended only as a general guide for the product described (herein). Any specific application should not be undertaken without independent study, evaluation, and testing for suitability.



4484 Boeing Drive Rockford, IL 61109 • USA • Phone +1 (815) 397-6628 • Fax +1 (815) 397-2526
 mail: delta@delta-power.com • www.delta-power.com



Via Malavolti, 36 • 41122 Modena • ITALY • Phone +39 (059) 254895 • Fax +39 (059) 253512
 mail: tecnord@tecnord.com • www.tecnord.com