

T-8A Cavity
Accepts Sun's
2 port Pilot
Control Cartridges
Pilot Control Cartridge
Sold Separately

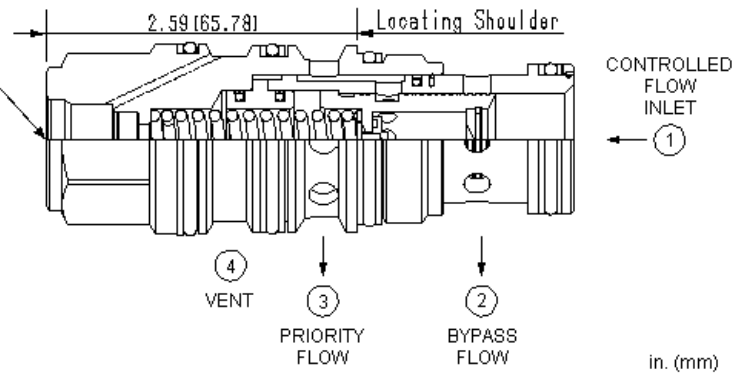

This valve is a ventable, bypass/restrictive, fixed-orifice, priority flow control with an integral pilot control cavity. The pilot control cavity will accept any T-8A pilot pressure or directional control cartridge. It takes an input flow at port 1 and uses it to satisfy the priority flow at port 3. If the input flow exceeds the priority flow requirement, the excess flow is bypassed out of port 2. Bypass flow may be used for a secondary circuit. Depending on which pilot control valve is installed in the T-8A cavity, priority flow can be selected electrically, manually, hydraulically or pneumatically.

TECHNICAL DATA

NOTE: DATA MAY VARY BY CONFIGURATION. SEE CONFIGURATION SECTION.

Maximum Operating Pressure	350 bar
Nominal Vent Flow	0,75 L/min.
Maximum Input Flow	240 L/min.
Pilot Control Cavity	T-8A
Pilot Control Valve Installation Torque	27 - 33 Nm
Pilot Control Valve Hex Size	22,2 mm
Seal kit - Cartridge	Buna: 990023007
Seal kit - Cartridge	Polyurethane: 990023002
Seal kit - Cartridge	Viton: 990023006

NOTES Compound cartridge (pilot and main stage) assembly information is provided for reference only. Cartridges must be ordered separately and assembled at point of use.

CONFIGURATION OPTIONS

Model Code Example: FVEA8AN

SETTING RANGE (A) SEAL MATERIAL (N)

A Replaceable Orifice .2 - 25 gpm (0,8 - 95 L/min.)

N Buna-N
V Viton

B Permanent Orifice .2 - 25 gpm (0,8 - 95 L/min.)