

SL-PLA SUPER SERIES, LOGIC VALVE

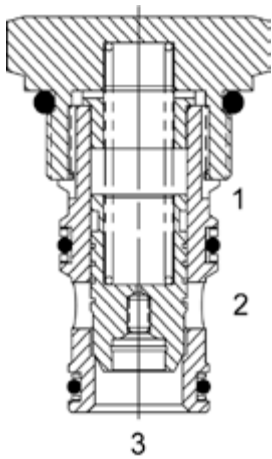

DESCRIPTION

16 size, 1 5/16-12 thread, "Super" series, logic valve.

OPERATION

The SL-PLA with an orifice between ports (3) and (1) maintains a constant flow rate from (3) regardless of load pressure changes in the system upstream of (3), or in the bypass leg at (2) as long as pressure at (2) is less than (1). Used for basic blocking applications.

FEATURES

- Hardened parts for long life.
- Industry common cavity.



For bidirectional applications see SL-PLC.
For metering see SLPCA or SL-PCB.

HYDRAULIC SYMBOL

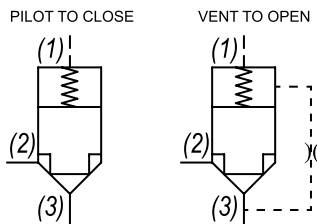

PERFORMANCE

Actual Test Data (Cartridge Only)

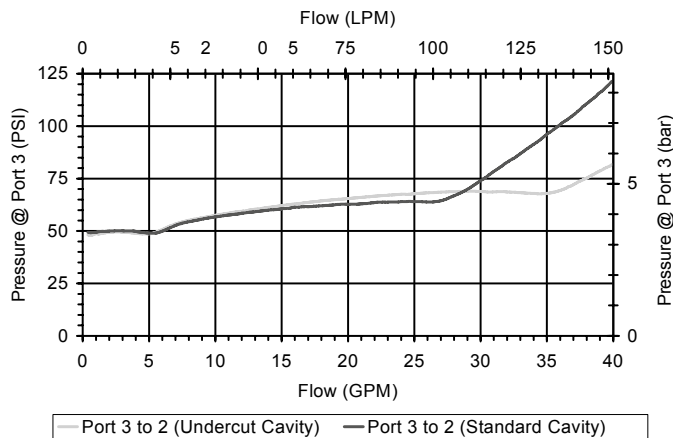

VALVE SPECIFICATIONS

Nominal Flow	40 GPM (151 LPM)
Rated Operating Pressure	3500 PSI (241 bar)
Viscosity Range	36 to 3000 SSU (3 to 647 cSt)
Filtration	ISO 18/16/13
Media Operating Temp. Range	-40° to 250°F (-40° to 120°C)
Weight	.69 lbs (.31 kg)
Operating Fluid Media	General Purpose Hydraulic Fluid
Cartridge Torque Requirements	90 ft-lbs (122 Nm)
Cavity	SUPER 3WS
Cavity Form Tool (Finishing)	40500021
Seal Kit	21191409
Seat Ratio	Area of the pilot is 1.2 times the area of the seat at Port (3)

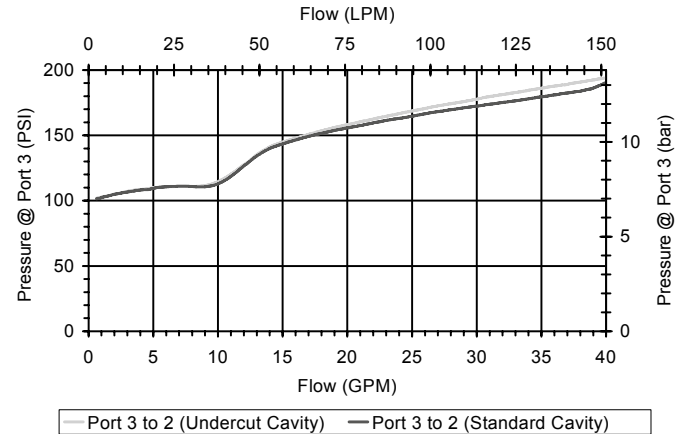

WARNING: the specifications/application data shown in our catalogs and data sheets are intended only as a general guide for the product described (herein). Any specific application should not be undertaken without independent study, evaluation, and testing for suitability.



4484 Boeing Drive Rockford, IL 61109 • USA • Phone +1 (815) 397-6628 • Fax +1 (815) 397-2526
mail: delta@delta-power.com • www.delta-power.com



Via Malavolti, 36 • 41122 Modena • ITALY • Phone +39 (059) 254895 • Fax +39 (059) 253512
mail: tecnord@tecnord.com • www.tecnord.com

DIMENSIONS

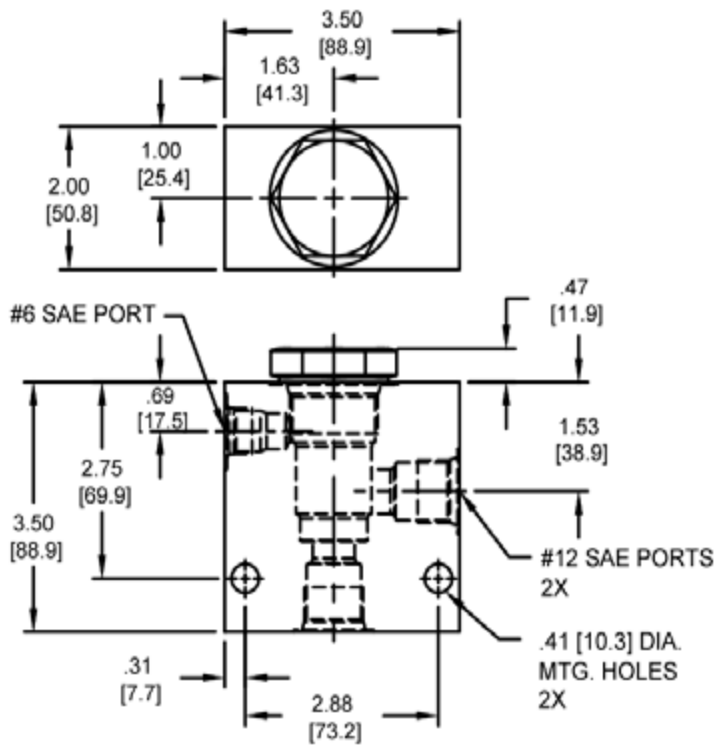
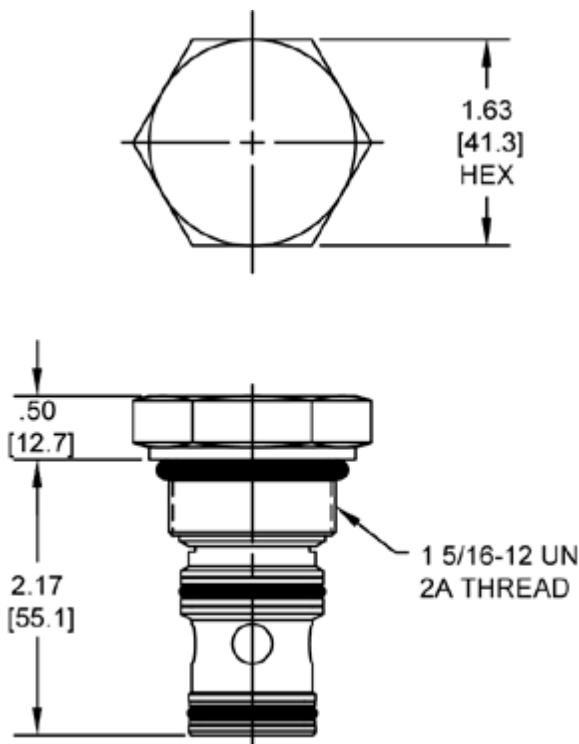

Body Weight: 1.89 lbs (.86 kg)

ORDERING INFORMATION

<p>SL-PLA -</p> <p>OPTIONS</p> <p>Buna, Pilot to Close OP</p> <p>Viton, Pilot to Close VP</p> <p>Buna, Vent to Open OV</p> <p>Viton, Vent to Open VV</p> <p>Buna, Pilot to Close w/seals OB</p> <p>Viton, Pilot to Close w/seals VB</p> <p>Buna, Vent to Open w/seals OC</p> <p>Viton, Vent to Open w/seals VC</p>	<p>-</p> <p>-</p> <p>-</p>	<p>BODIES</p> <p>Blank Without Body</p> <p>S #12 SAE Ports</p> <p>PRESSURE SETTING</p> <p>0020 20 PSI</p> <p>0050 50 PSI</p> <p>0100 100 PSI</p> <p>0150 150 PSI</p>
--	----------------------------	--

W 15 / 2017

WARNING: the specifications/application data shown in our catalogs and data sheets are intended only as a general guide for the product described (herein). Any specific application should not be undertaken without independent study, evaluation, and testing for suitability.



4484 Boeing Drive Rockford, IL 61109 • USA • Phone +1 (815) 397-6628 • Fax +1 (815) 397-2526
 mail: delta@delta-power.com • www.delta-power.com



Via Malavolti, 36 • 41122 Modena • ITALY • Phone +39 (059) 254895 • Fax +39 (059) 253512
 mail: tecnord@tecnord.com • www.tecnord.com