

3-Port Non-vented, Fixed Setting

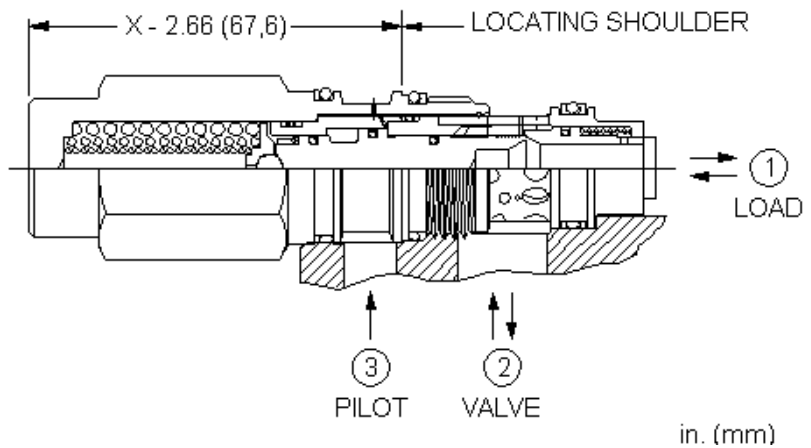

Fixed setting, load reactive, load control valves with pilot assist combine two valves; a check valve and a relief valve. The check valve allows free flow from the directional valve (port 2) to the load (port 1) while a direct-acting, pilot-assisted relief valve controls flow from port 1 to port 2. Pilot assist at port 3 lowers the effective setting of the relief valve at a rate determined by the pilot ratio.

TECHNICAL DATA

NOTE: DATA MAY VARY BY CONFIGURATION. SEE CONFIGURATION SECTION.

Pilot Ratio	1.5:1
Factory Pressure Settings Established at	30 cc/min.
Maximum Valve Leakage at Reseat	0,3 cc/min.
Check Cracking Pressure	1,7 bar
Reseat	>85% of setting
Seal kit - Cartridge	Buna: 990202007
Seal kit - Cartridge	Polyurethane: 990002002
Seal kit - Cartridge	Viton: 990202006

CONFIGURATION OPTIONS

Model Code Example: **MBEBXLN**

FACTORY SET	(L)	SEAL MATERIAL	(N)
L 4000 psi (280 bar)		N Buna-N	
K 3000 psi (210 bar)		V Viton	
M 5000 psi (350 bar)			