

3-Port Non-vented, Fixed Setting

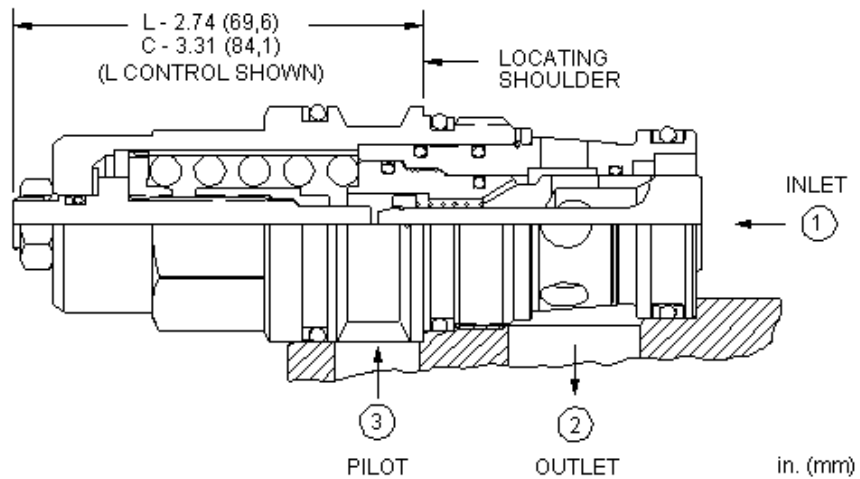

Counterbalance valves with pilot assist are meant to control an overrunning load. The check valve allows free flow from the directional valve (port 2) to the load (port 1) while a direct-acting, pilot-assisted relief valve controls flow from port 1 to port 2. Pilot assist at port 3 lowers the effective setting of the relief valve at a rate determined by the pilot ratio.

Other names for this valve include motion control valve and over-center valve.

TECHNICAL DATA

NOTE: DATA MAY VARY BY CONFIGURATION. SEE CONFIGURATION SECTION.

Pilot Ratio	3:1
Maximum Recommended Load Pressure at Maximum Setting	215 bar
Maximum Setting	280 bar
Factory Pressure Settings Established at	30 cc/min.
Maximum Valve Leakage at Reseat	0,3 cc/min.
Adjustment - Number of Counterclockwise Turns to Increase Setting	3.75
Reseat	>85% of setting
Locknut Hex Size	15 mm
Locknut Torque	9 - 10 Nm
Seal kit - Cartridge	Buna: 990017007
Seal kit - Cartridge	Polyurethane: 990017002
Seal kit - Cartridge	Viton: 990017006

CONFIGURATION OPTIONS

Model Code Example: CBFALHN

CONTROL	(L) FUNCTIONAL SETTING RANGE	(H) SEAL MATERIAL	(N) MATERIAL/COATING
L Standard Screw Adjustment	H 1000 - 4000 psi w/25 psi Check (70 - 280 bar w/ 1,7 bar Check), 3000 psi (210 bar) Standard Setting	N Buna-N	Standard Material/Coating
C Tamper Resistant - Factory Set	A 1000 - 4000 psi w/4 psi Check (70 - 280 bar w/ 0,3 bar Check), 3000 psi (210 bar) Standard Setting	V Viton	/AP Stainless Steel, Passivated /LH Mild Steel, Zinc-Nickel
	B 400 - 1500 psi w/4 psi Check (28 - 105 bar w/ 0,3 bar Check), 1000 psi (70 bar) Standard Setting		
	I 400 - 1500 psi w/25 psi Check (28 - 105 bar w/ 1,7 bar Check), 1000 psi (70 bar) Standard Setting		