

3-Port Atmospherically Referenced

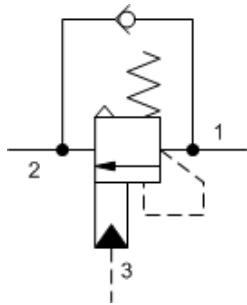

3-Port Atmospherically Referenced, Non-adjustable

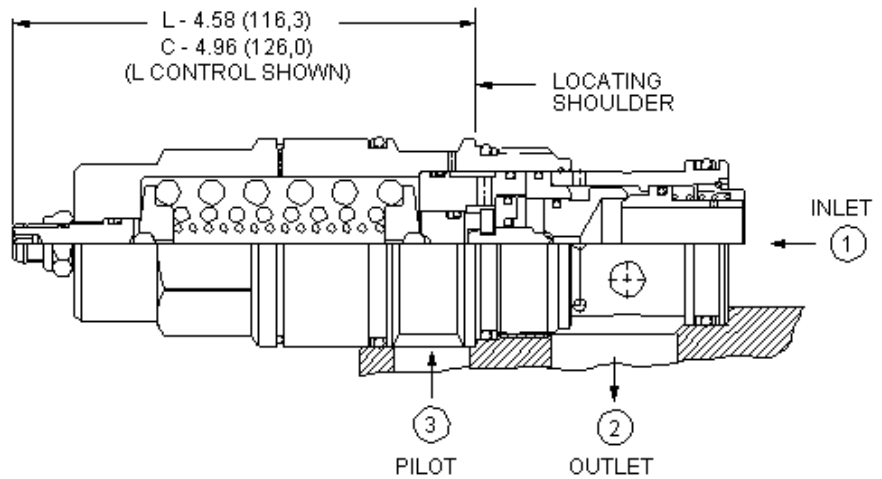

Atmospherically vented counterbalance valves with pilot assist are meant to control an overrunning load. The check valve allows free flow from the directional valve (port 2) to the load (port 1) while a direct-acting, pilot-assisted relief valve controls flow from port 1 to port 2. Pilot assist at port 3 lowers the effective setting of the relief valve at a rate determined by the pilot ratio. Backpressure at port 2 does not affect the valve setting because the spring chamber is atmospherically referenced.

Other names for this valve include motion control valve and over-center valve.

TECHNICAL DATA

NOTE: DATA MAY VARY BY CONFIGURATION. SEE CONFIGURATION SECTION.

Pilot Ratio	1:1
Maximum Recommended Load Pressure at Maximum Setting	215 bar
Maximum Setting	280 bar
Factory Pressure Settings Established at	30 cc/min.
Maximum Valve Leakage at Reseat	0,3 cc/min.
Check Cracking Pressure	1,5 bar
Adjustment - Number of Counterclockwise Turns to Increase Setting	5
Reseat	>85% of setting
Locknut Hex Size	15 mm
Locknut Torque	9 - 10 Nm
Seal kit - Cartridge	Buna: 990119007
Seal kit - Cartridge	Polyurethane: 990119002
Seal kit - Cartridge	Viton: 990119006

CONFIGURATION OPTIONS

Model Code Example: CAIKLHN

CONTROL	(L) FUNCTIONAL SETTING RANGE	(H) SEAL MATERIAL	(N)
L Standard Screw Adjustment	H 1000 - 4000 psi (70 - 280 bar), 3000 psi (210 bar) Standard Setting	N Buna-N	
C Tamper Resistant - Factory Set		V Viton	

I 400 - 1500 psi (28 - 105 bar), 1000 psi (70 bar) Standard Setting