

**DF-CPC PILOT TO OPEN, CHECK VALVE, GUIDED BALL**

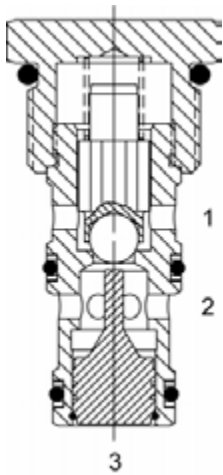

**DESCRIPTION**

10 size, 7/8-14 thread, "Delta" series, pilot to open, ball check valve.

**OPERATION**

The DF-CPC allows free flow to pass from (2) to (1) and blocks flow from (1) to (2). When pilot pressure is applied to port (3) the valve allows free flow from (1) to (2). The cartridge has a 2:1 pilot ratio, meaning that at least one half of the load pressure held at (1) is required at (3) to open the valve. The check is spring biased to assure holding in static or no-load conditions.

**FEATURES**

- Hardened parts for long life.
- Industry common cavity.

**HYDRAULIC SYMBOL**

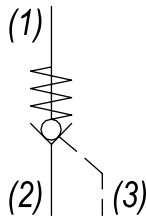

*Special higher bias spring values available. Consult factory. For sealed pilot piston consult factory.*

**PERFORMANCE**

Actual Test Data (Cartridge Only)

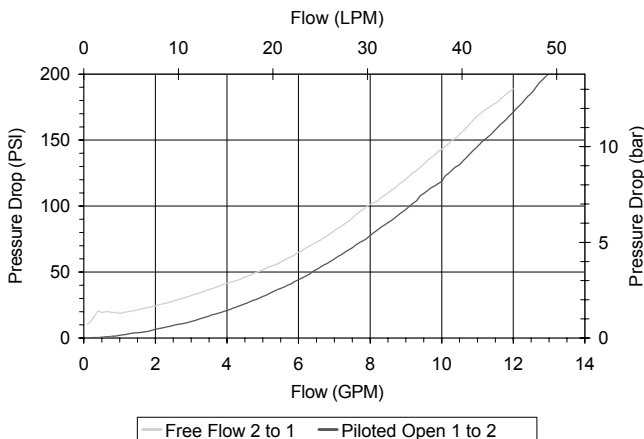

**VALVE SPECIFICATIONS**

Nominal Flow	10 GPM (38 LPM)
Rated Operating Pressure	3500 PSI (241 bar)
Typical Internal Leakage (150 SSU)	0-5 drops/min
Pilot Ratio	2:1
Viscosity Range	36 to 3000 SSU (3 to 647 cSt)
Filtration	ISO 18/16/13
Media Operating Temp. Range	-40° to 250°F (-40° to 120°C)
Weight	.19 lbs (.09 kg)
Operating Fluid Media	General Purpose Hydraulic Fluid
Cartridge Torque Requirements	30 ft-lbs (40.6 Nm)
Cavity	DELTA 3W
Cavity Form Tool (Finishing)	40500001
Seal Kit	21191202

**WARNING:** the specifications/application data shown in our catalogs and data sheets are intended only as a general guide for the product described (herein). Any specific application should not be undertaken without independent study, evaluation, and testing for suitability.



4484 Boeing Drive Rockford, IL 61109 • USA • Phone +1 (815) 397-6628 • Fax +1 (815) 397-2526  
 mail: delta@delta-power.com • www.delta-power.com



Via Malavolti, 36 • 41122 Modena • ITALY • Phone +39 (059) 254895 • Fax +39 (059) 253512  
 mail: tecnord@tecnord.com • www.tecnord.com

DIMENSIONS

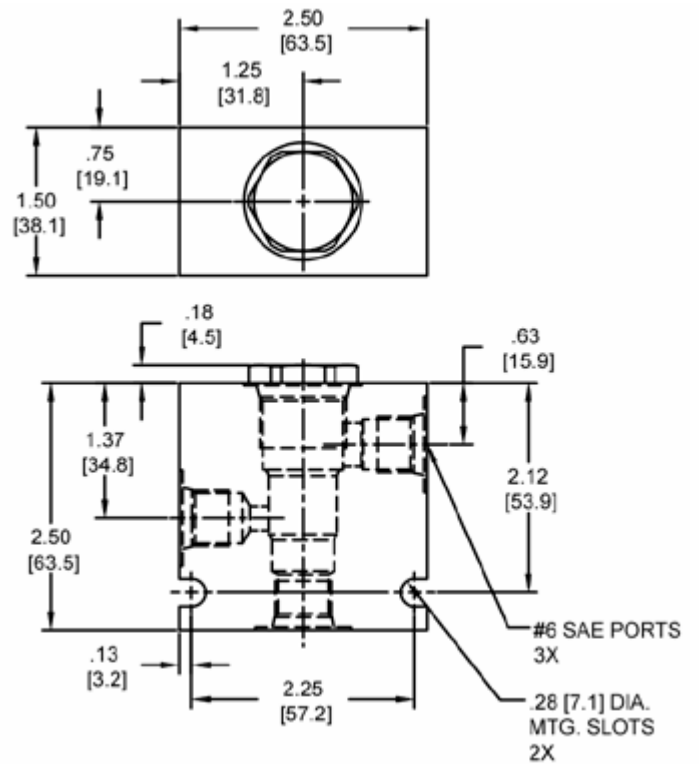
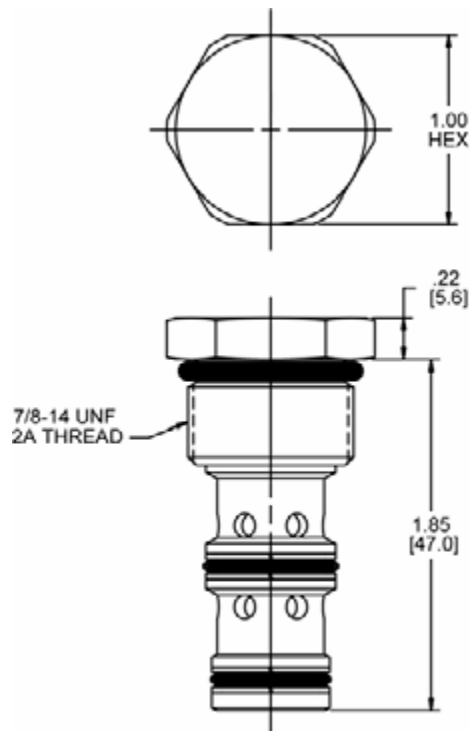

ORDERING INFORMATION

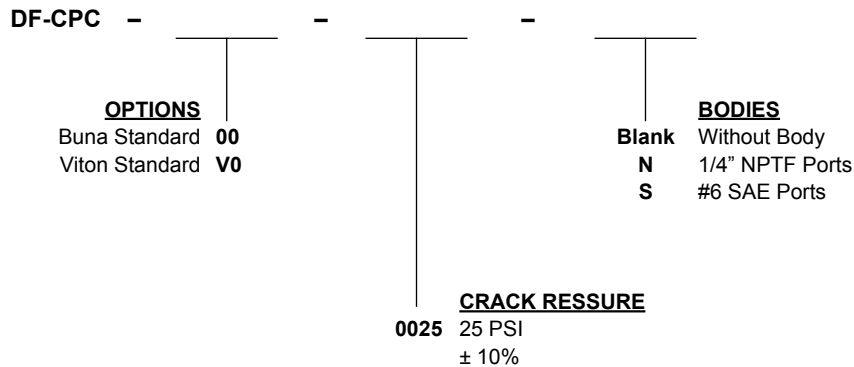

W 40 / 2017

**WARNING:** the specifications/application data shown in our catalogs and data sheets are intended only as a general guide for the product described (herein). Any specific application should not be undertaken without independent study, evaluation, and testing for suitability.



4484 Boeing Drive Rockford, IL 61109 • USA • Phone +1 (815) 397-6628 • Fax +1 (815) 397-2526  
mail: delta@delta-power.com • www.delta-power.com



Via Malavolti, 36 • 41122 Modena • ITALY • Phone +39 (059) 254895 • Fax +39 (059) 253512  
mail: tecnord@tecnord.com • www.tecnord.com