

SL-CPD PILOT TO CLOSE CHECK VALVE, POPPET

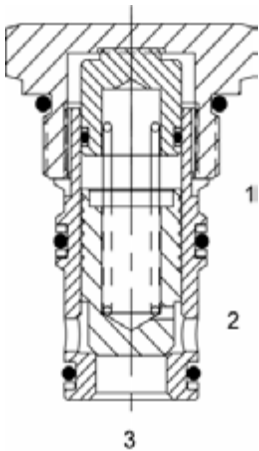

DESCRIPTION

16 size, 1 5/16-12 thread, "Super" series, pilot to close, poppet check valve.

OPERATION

The SL-CPD allows free flow from (3) to (2), and blocks flow from (2) to (3). Flow will be blocked from (3) to (2) when sufficient pressure is applied at (1). The cartridge has a 2:1 pilot ratio, meaning that at least one half of the load pressure held at (3) is required at (1) to close the valve. The check is spring biased to assure holding in static or no-load conditions.

FEATURES

- Hardened seat for long life.
- Industry common cavity.

HYDRAULIC SYMBOL

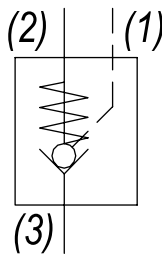

Special higher bias spring values available. Consult factory.

PERFORMANCE

Actual Test Data (Cartridge Only)

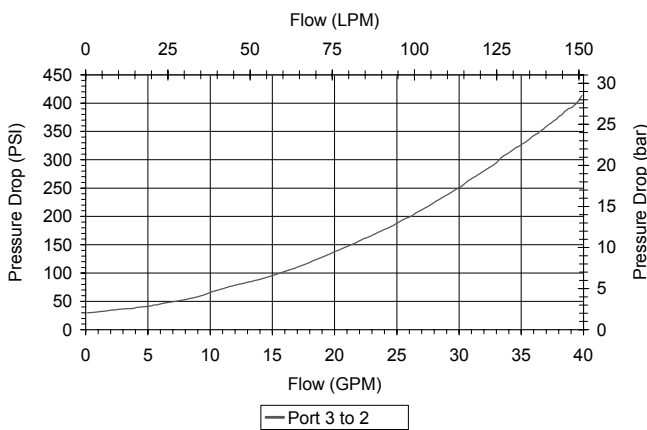

VALVE SPECIFICATIONS

Nominal Flow	20 GPM (76 LPM)
Rated Operating Pressure	3500 PSI (241 bar)
Typical Internal Leakage (150 SSU)	5 drops/min
Pilot Ratio	2:1
Viscosity Range	36 to 3000 SSU (3 to 647 cSt)
Filtration	ISO 18/16/13
Media Operating Temp. Range	-40° to 250°F (-40° to 120°C)
Weight	.68 lbs (.31 kg)
Operating Fluid Media	General Purpose Hydraulic Fluid
Cartridge Torque Requirements	90 ft-lbs (122 Nm)
Cavity	SUPER 3WS
Cavity Form Tool (Finishing)	40500021
Seal Kit	21191404

WARNING: the specifications/application data shown in our catalogs and data sheets are intended only as a general guide for the product described (herein). Any specific application should not be undertaken without independent study, evaluation, and testing for suitability.



4484 Boeing Drive Rockford, IL 61109 • USA • Phone +1 (815) 397-6628 • Fax +1 (815) 397-2526
mail: delta@delta-power.com • www.delta-power.com



Via Malavolti, 36 • 41122 Modena • ITALY • Phone +39 (059) 254895 • Fax +39 (059) 253512
mail: tecnord@tecnord.com • www.tecnord.com

DIMENSIONS

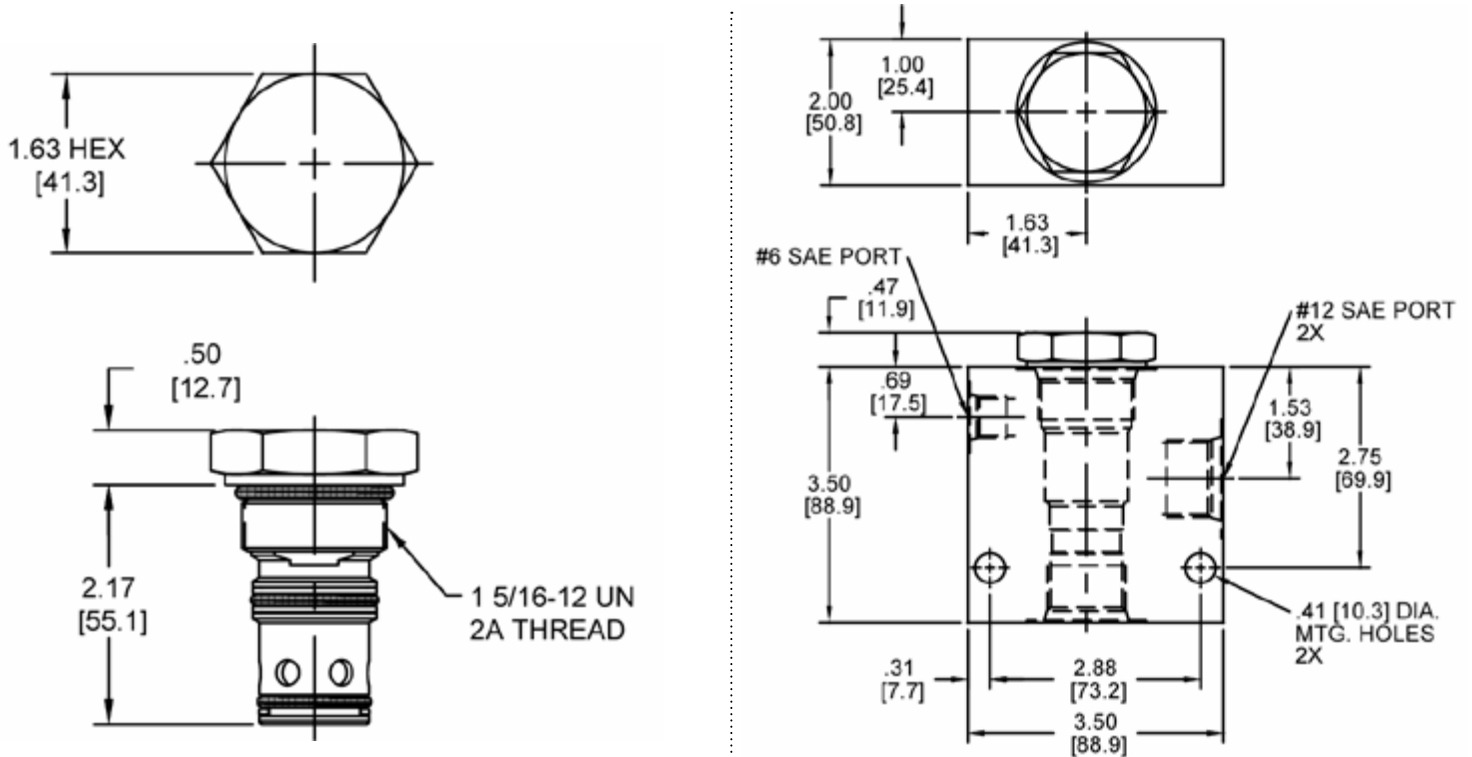

Body Weight: 1.89 lbs (.86 kg)

ORDERING INFORMATION

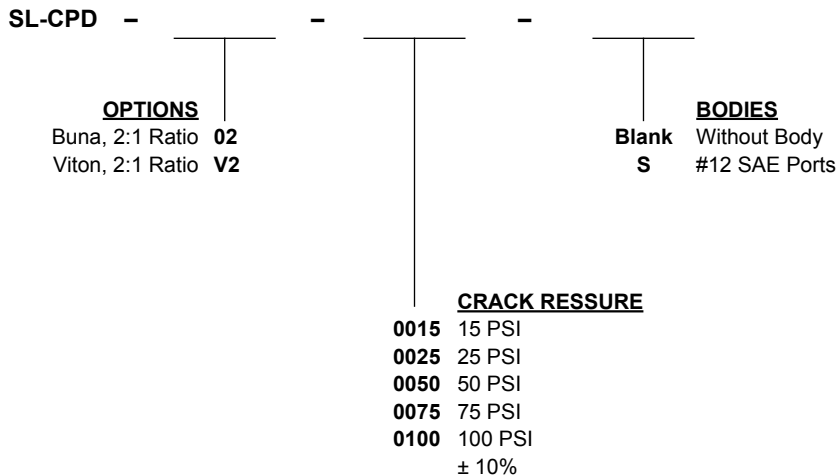

W 40 / 2017

WARNING: the specifications/application data shown in our catalogs and data sheets are intended only as a general guide for the product described (herein). Any specific application should not be undertaken without independent study, evaluation, and testing for suitability.



4484 Boeing Drive Rockford, IL 61109 • USA • Phone +1 (815) 397-6628 • Fax +1 (815) 397-2526
 mail: delta@delta-power.com • www.delta-power.com



Via Malavolti, 36 • 41122 Modena • ITALY • Phone +39 (059) 254895 • Fax +39 (059) 253512
 mail: tecnord@tecnord.com • www.tecnord.com