

3-Port Atmospherically Referenced

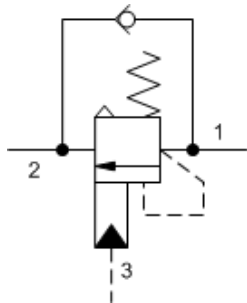

3-Port Atmospherically Referenced, Non-adjustable

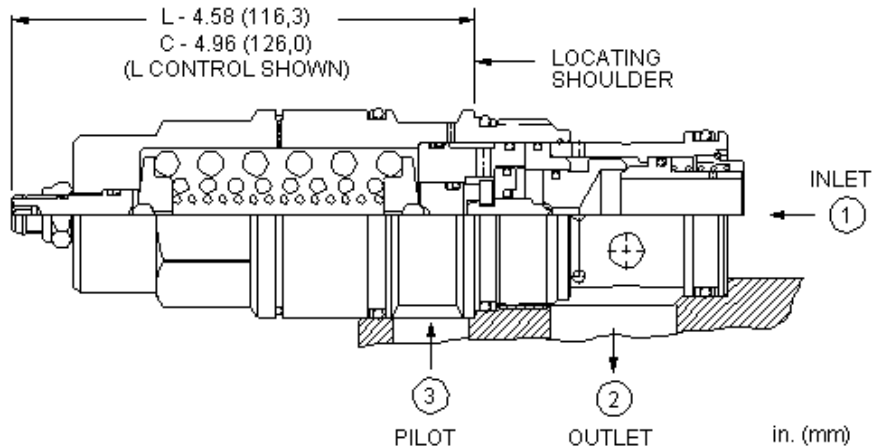

Atmospherically vented counterbalance valves with pilot assist are meant to control an overrunning load. The check valve allows free flow from the directional valve (port 2) to the load (port 1) while a direct-acting, pilot-assisted relief valve controls flow from port 1 to port 2. Pilot assist at port 3 lowers the effective setting of the relief valve at a rate determined by the pilot ratio. Backpressure at port 2 does not affect the valve setting because the spring chamber is atmospherically referenced.

Other names for this valve include motion control valve and over-center valve.

**TECHNICAL DATA**

NOTE: DATA MAY VARY BY CONFIGURATION. SEE CONFIGURATION SECTION.

Pilot Ratio	2:1
Maximum Recommended Load Pressure at Maximum Setting	320 bar
Maximum Setting	420 bar
Factory Pressure Settings Established at	30 cc/min.
Maximum Valve Leakage at Reseat	0,3 cc/min.
Check Cracking Pressure	1,5 bar
Adjustment - Number of Counterclockwise Turns to Increase Setting	5
Reseat	>85% of setting
Locknut Hex Size	15 mm
Locknut Torque	9 - 10 Nm
Seal kit - Cartridge	Buna: 990119007
Seal kit - Cartridge	Polyurethane: 990119002
Seal kit - Cartridge	Viton: 990119006

**CONFIGURATION OPTIONS**

**Model Code Example: CAILGN**

CONTROL	(L) FUNCTIONAL SETTING RANGE	(G) SEAL MATERIAL	(N) MATERIAL/COATING
L Standard Screw Adjustment	G 2000 - 6000 psi (140 - 420 bar), 4000 psi (280 bar) Standard Setting	N Buna-N	Standard Material/Coating
C Tamper Resistant - Factory Set	F 1000 - 2500 psi (70 - 175 bar), 2000 psi (140 bar) Standard Setting	V Viton	/LH Mild Steel, Zinc-Nickel