

3-Port Atmospherically Referenced

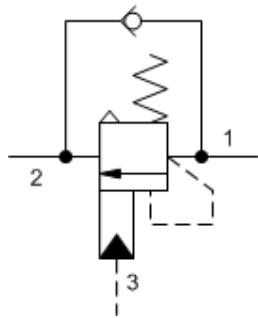

3-Port Atmospherically Referenced, Non-adjustable

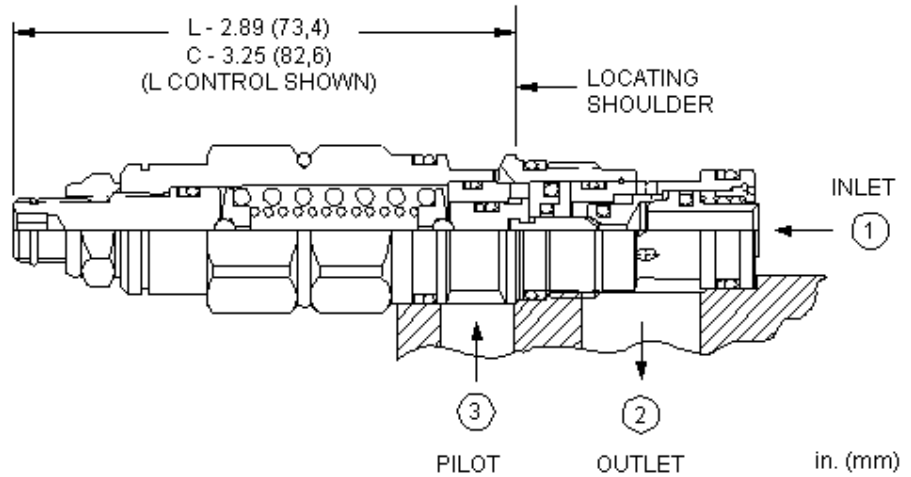

Atmospherically-vented counterbalance valves with pilot assist are meant to control an overrunning load. The check valve allows free flow from the directional valve (port 2) to the load (port 1) while a direct-acting, pilot-assisted relief valve controls flow from port 1 to port 2. Pilot assist at port 3 lowers the effective setting of the relief valve at a rate determined by the pilot ratio. Backpressure at port 2 does not affect the valve setting because the spring chamber is atmospherically referenced.

Other names for this valve include motion control valve and over center valve.

TECHNICAL DATA

Pilot Ratio	1:1
Maximum Recommended Load Pressure at Maximum Setting	215 bar
Maximum Setting	280 bar
Factory Pressure Settings Established at	30 cc/min.
Maximum Valve Leakage at Reseat	0,3 cc/min.
Check Cracking Pressure	2,8 bar
Adjustment - Number of Counterclockwise Turns to Increase Setting	5
Reseat	>85% of setting
Locknut Hex Size	15 mm
Locknut Torque	9 - 10 Nm
Seal kit - Cartridge	Buna: 990-211-007
Seal kit - Cartridge	Viton: 990-211-006

CONFIGURATION OPTIONS

Model Code Example: CACKLHN

CONTROL

- L** Standard Screw Adjustment
- C** Tamper Resistant - Factory Set

FUNCTIONAL SETTING RANGE

- H** 1000 - 4000 psi (70 - 280 bar), 3000 psi (210 bar) Standard Setting
- I** 400 - 1500 psi (28 - 105 bar), 1000 psi (70 bar) Standard Setting

SEAL MATERIAL

- N** Buna-N
- V** Viton

MATERIAL/COATING

- (none)** Standard Material/Coating
- /LH** Mild Steel, Zinc-Nickel

TECHNICAL FEATURES

- Counterbalance valves should be set at least 1.3 times the maximum load induced pressure.
- Turn adjustment clockwise to decrease setting and release load.
- Full clockwise setting is 200 psi (14 bar).
- Approximately 1 drop (0,07 cc) of fluid will pass from the pilot area to the vented spring chamber every 4000 cycles.
- Reseat exceeds 85% of set pressure when the valve is standard set. Settings lower than the standard set pressure may result in lower reseal percentages.

- Sun counterbalance cartridges can be installed directly into a cavity machined in an actuator housing for added protection and improved stiffness in the circuit.
- This valve has positive seals between all ports.
- With vented valves, a lower pilot ratio may be required to achieve machine stability compared to non-vented valves.
- Three-port vented valves are atmospherically referenced and considered problem solvers for existing circuits using non-vented valves. Over time, the vented valves may leak externally or allow moisture into the spring chamber. Four-port vented counterbalance valves are recommended for new applications.
- All 3-port counterbalance, load control, and pilot-to-open check cartridges are physically interchangeable (i.e. same flow path, same cavity for a given frame size).
- Incorporates the Sun floating style construction to minimize the possibility of internal parts binding due to excessive installation torque and/or cavity/cartridge machining variations.

PERFORMANCE CURVES

Free Flow and Piloted Open Pressure Drop

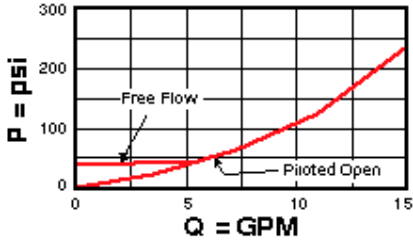

Free Flow and Piloted Open Pressure Drop

